

MODULO BASE

egò



ATTENZIONE:
prima dell'installazione verificate il tipo di muro. I tasselli forniti nelle confezioni sono collaudati su muro in calcestruzzo o mattoni pieni. Per l'installazione su mattoni forati utilizzare tasselli specifici che garantiscano un carico a trazione di 2,5 Kn.



WARNING:
before installing check the type of wall. The metallic rawlplugs supplied in the packages are for concrete or full brick walls. For installation on hollow brick walls use the necessary specific rawlplugs that guarantee a ractive load of 2,5 Kn.

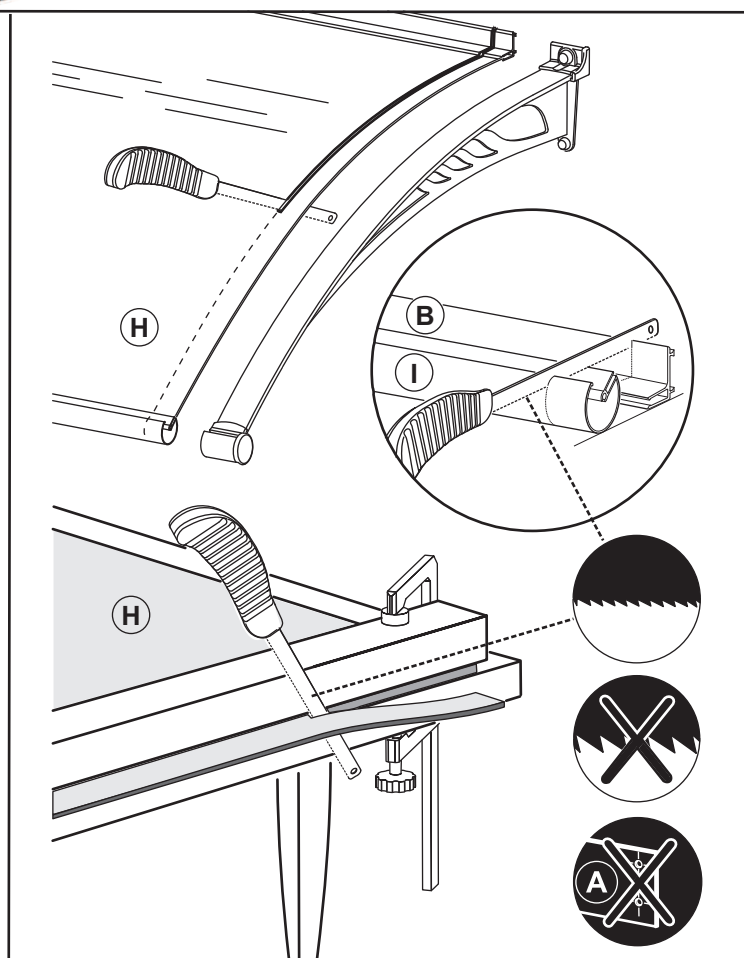
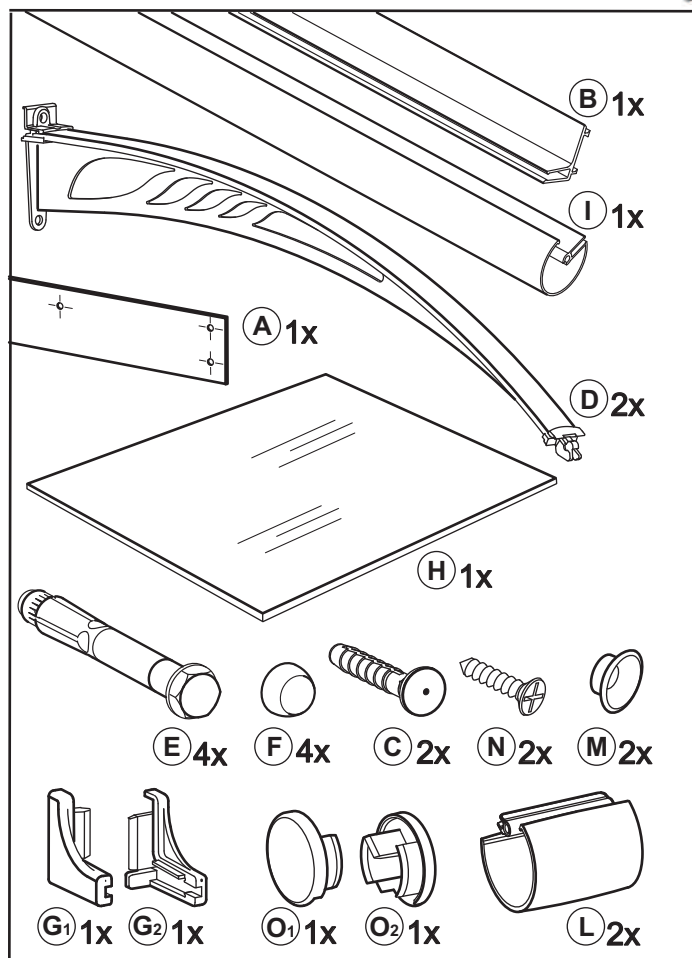

Art.is.ego001

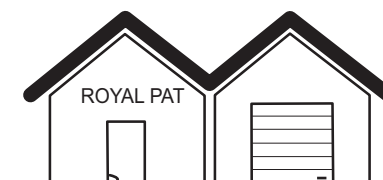

Tel.+39 0734 628303 info@royalpat.it www.royalpat.it

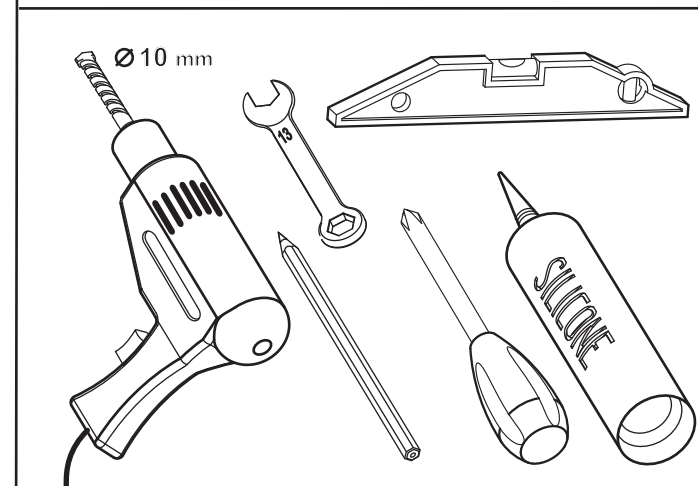

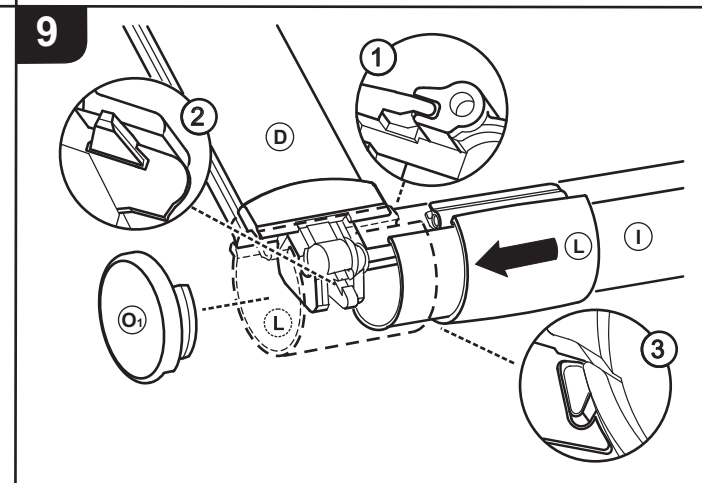
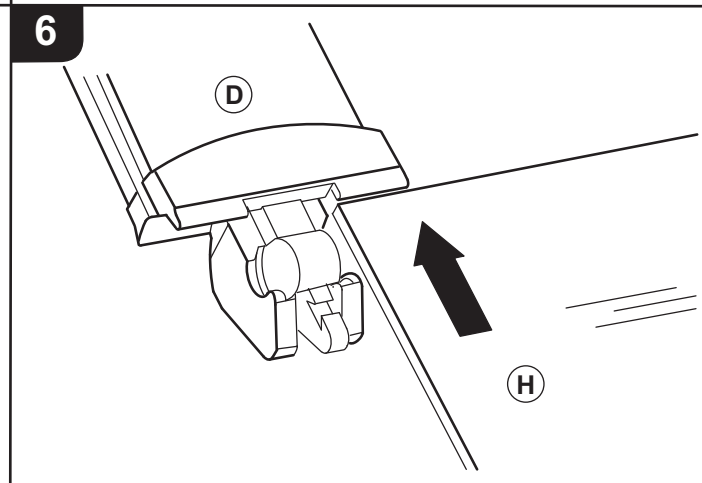
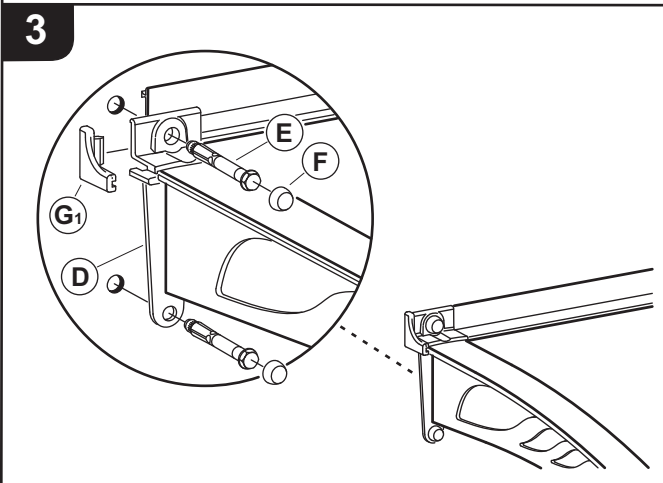
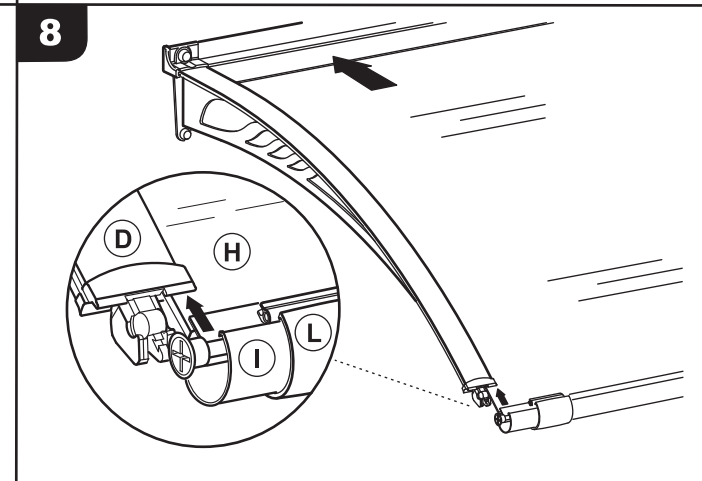
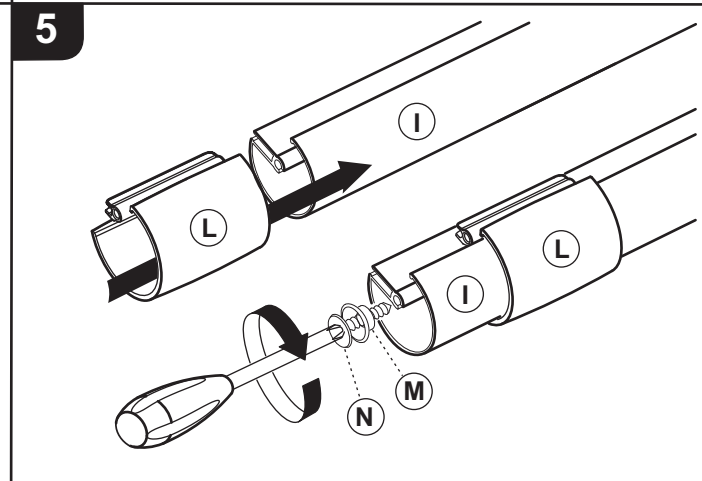
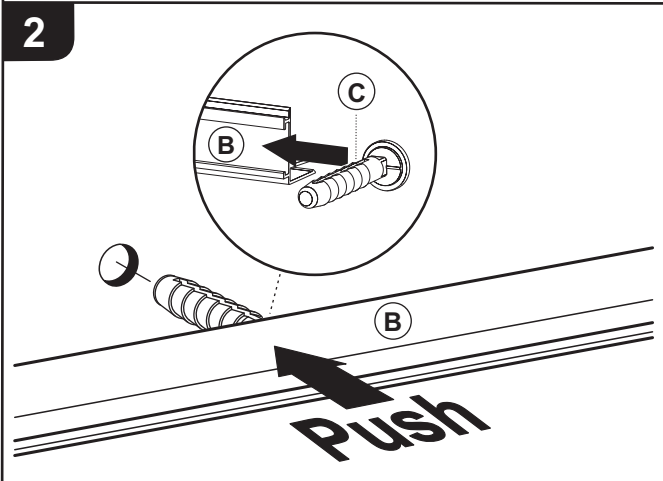
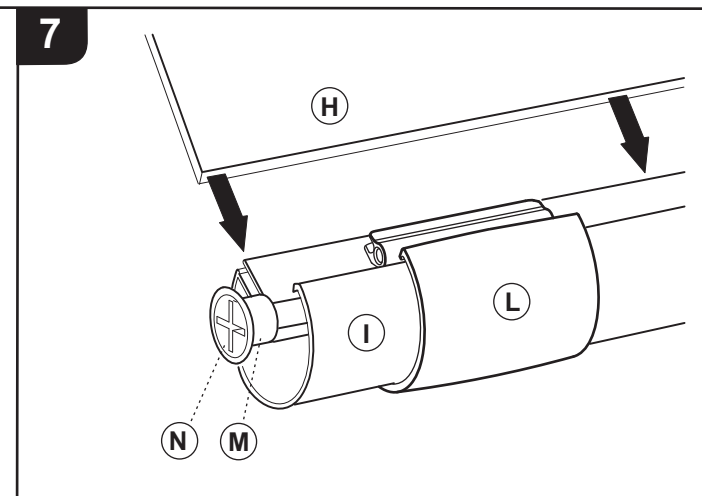
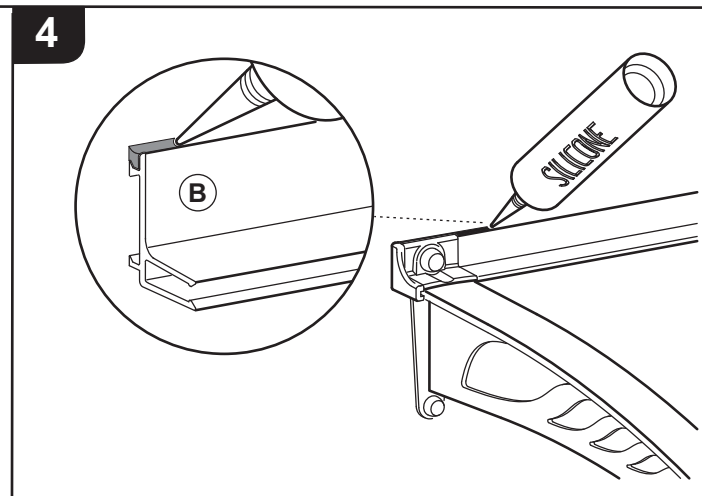
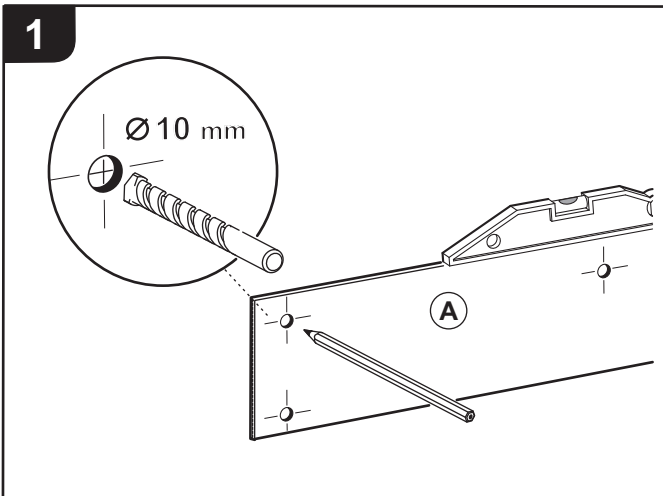

MODULO AGGIUNTIVO

egò

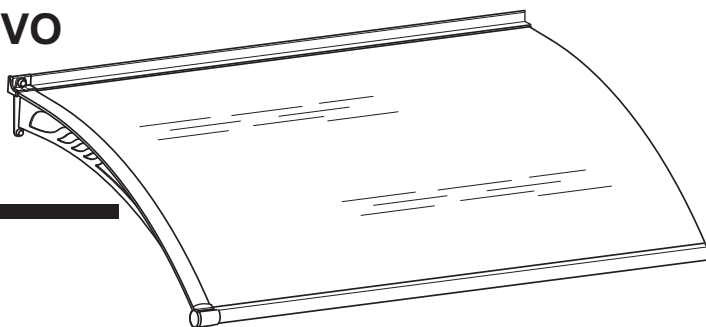

ATTENZIONE:
prima dell'installazione verificate il tipo di muro. I tasselli forniti nelle confezioni sono collaudati su muro in calcestruzzo o mattoni pieni. Per l'installazione su mattoni forati utilizzare tasselli specifici che garantiscano un carico a trazione di 2,5 Kn.



WARNING:
before installing check the type of wall. The metallic rawlplugs supplied in the packages are for concrete or full brick walls. For installation on hollow brick walls use the necessary specific rawlplugs that guarantee a ractive load of 2,5 Kn.

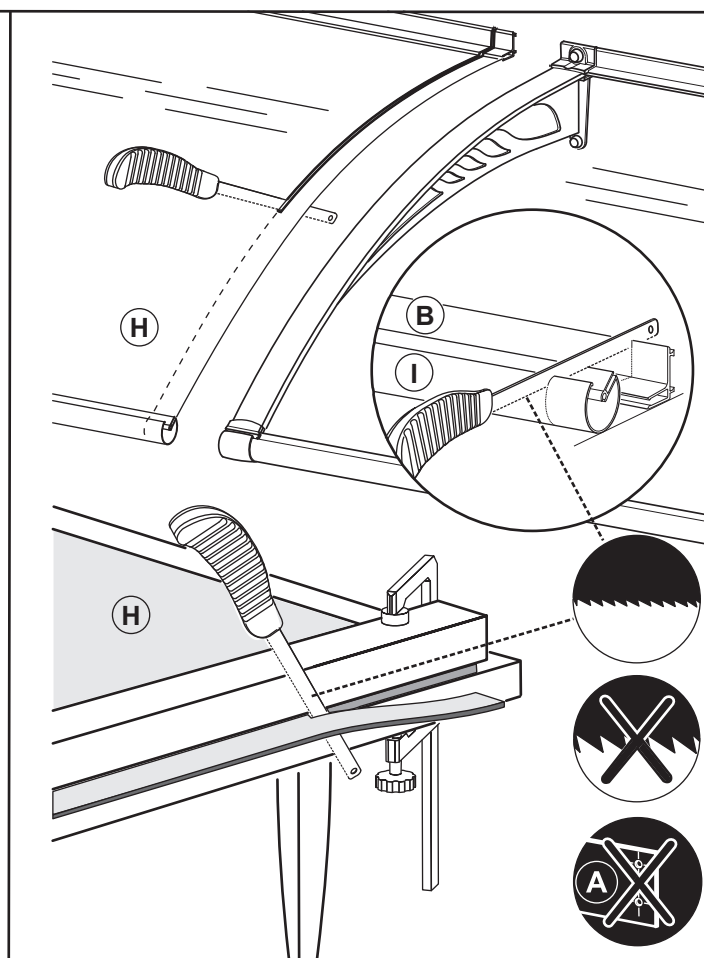
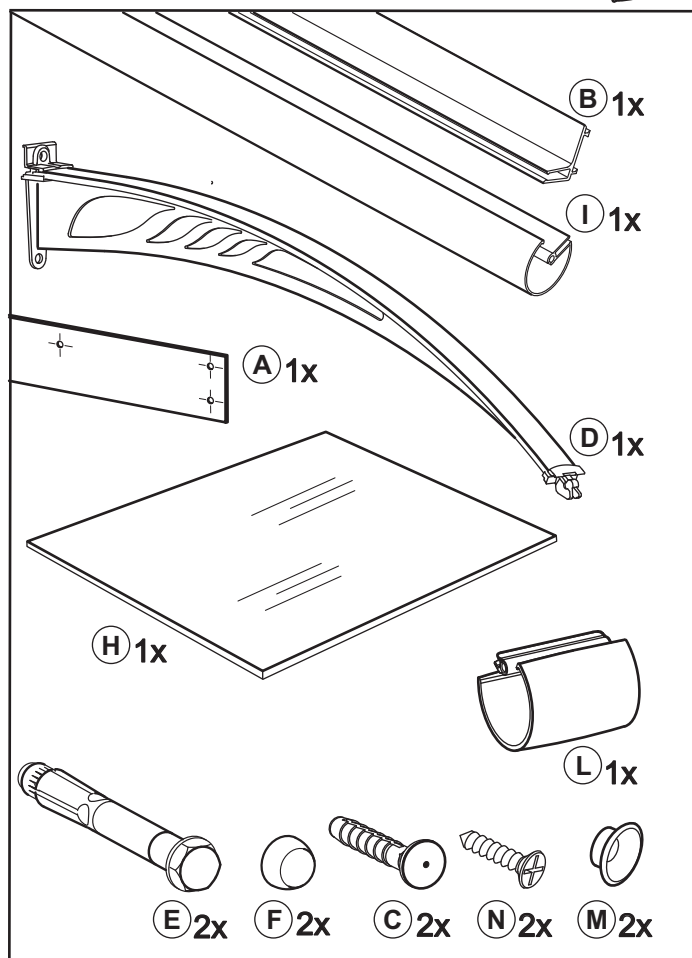

Art.is.ego0002

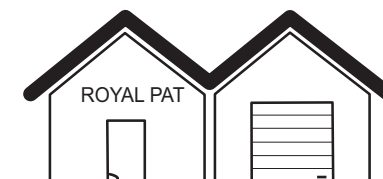

Tel.+39 0734 628303 info@royalpat.it www.royalpat.it

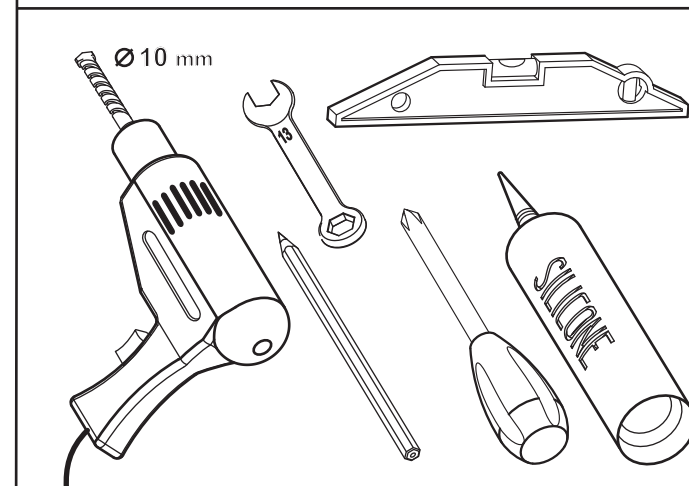

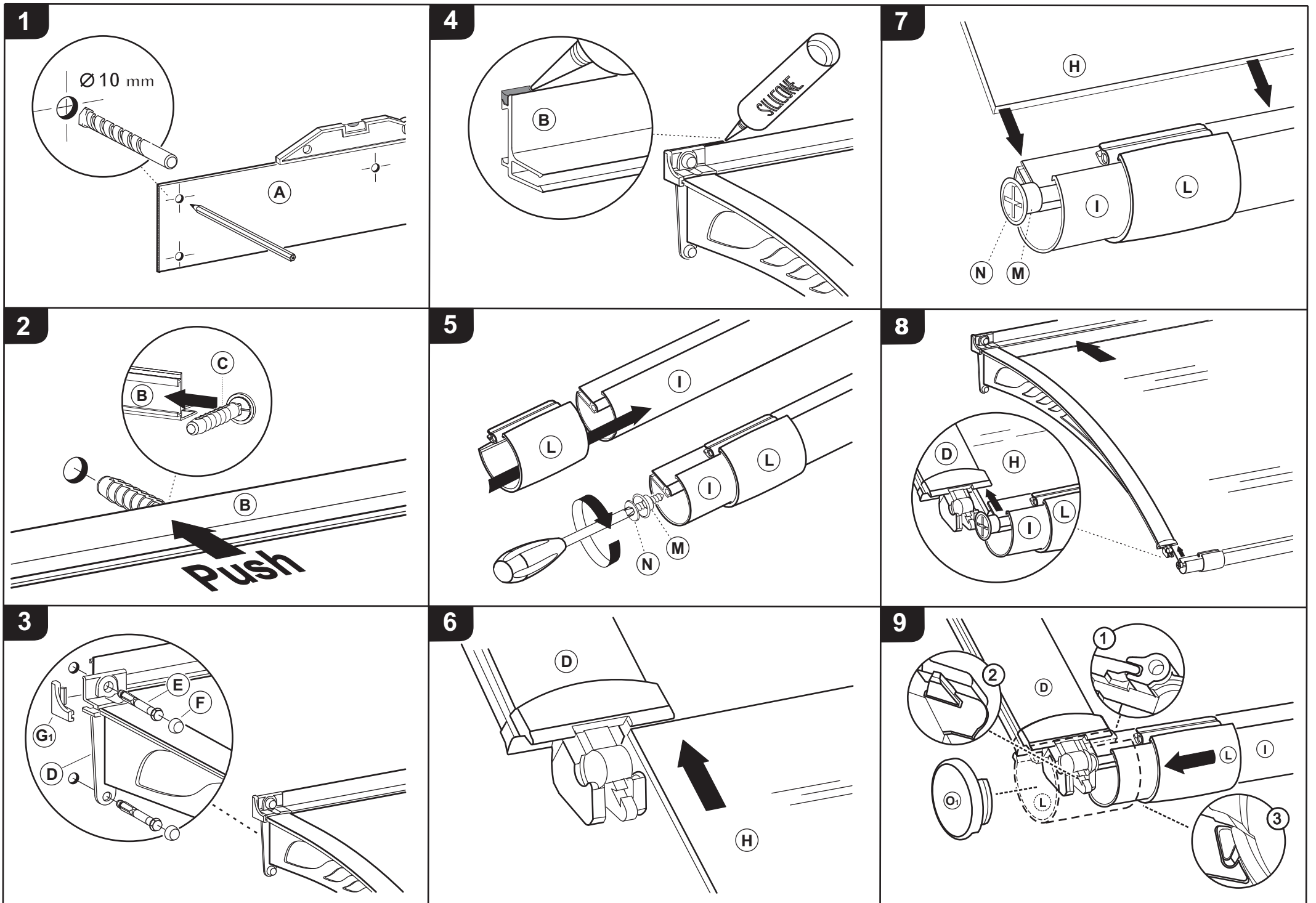

FLAP LATERALI

egò

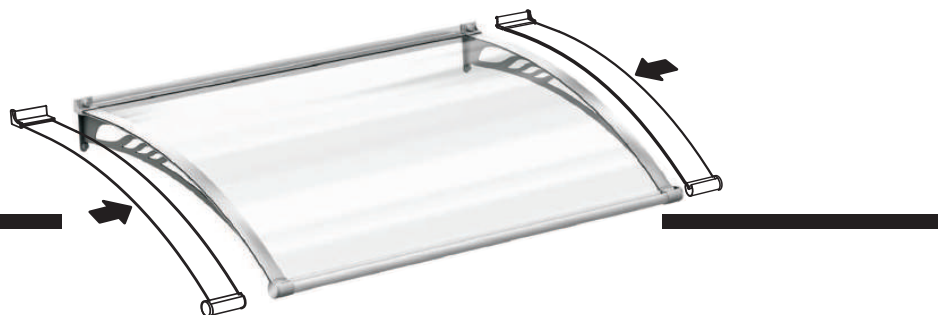

Art.is.ego0003

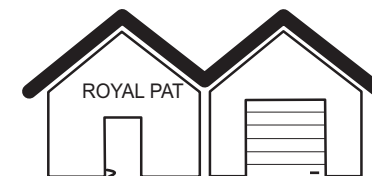

Tel. +39 0734 628303 info@royalpat.it www.royalpat.it

